

0920  
Lunchbox Trolley



**Assembly Instructions.**

Please read these instructions carefully before assembling the unit and where necessary refer to the enclosed Component List.

**Additional tools required**

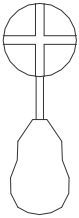

**Adults required for assembly**

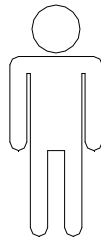

**Maintenance.**

Some residual dust from the manufacturing process may be apparent. Your unit may be cleaned with a damp cloth. Stubborn marks may be removed with a mild detergent, or non-abrasive cream cleaner. Examine all fasteners periodically and retighten if necessary.

This unit is designed for use indoors on a flat and level surface.

Please retain our address for future reference

Manufactured by:  
Mike Miller Associates Ltd.,  
Syke Road, Wigton. Cumbria CA7 9NS  
Tel: 016973 49774/45300 Fax: 016973 45511  
Email: [info@twoeytoys.com](mailto:info@twoeytoys.com)  
Website: [www.twoeytoys.com](http://www.twoeytoys.com)  
Registered in England No: 1425839  
Registered Office: The Old Brewery, Caldbeck.  
Cumbria CA7 8EW

Please refer to the attached Component List.

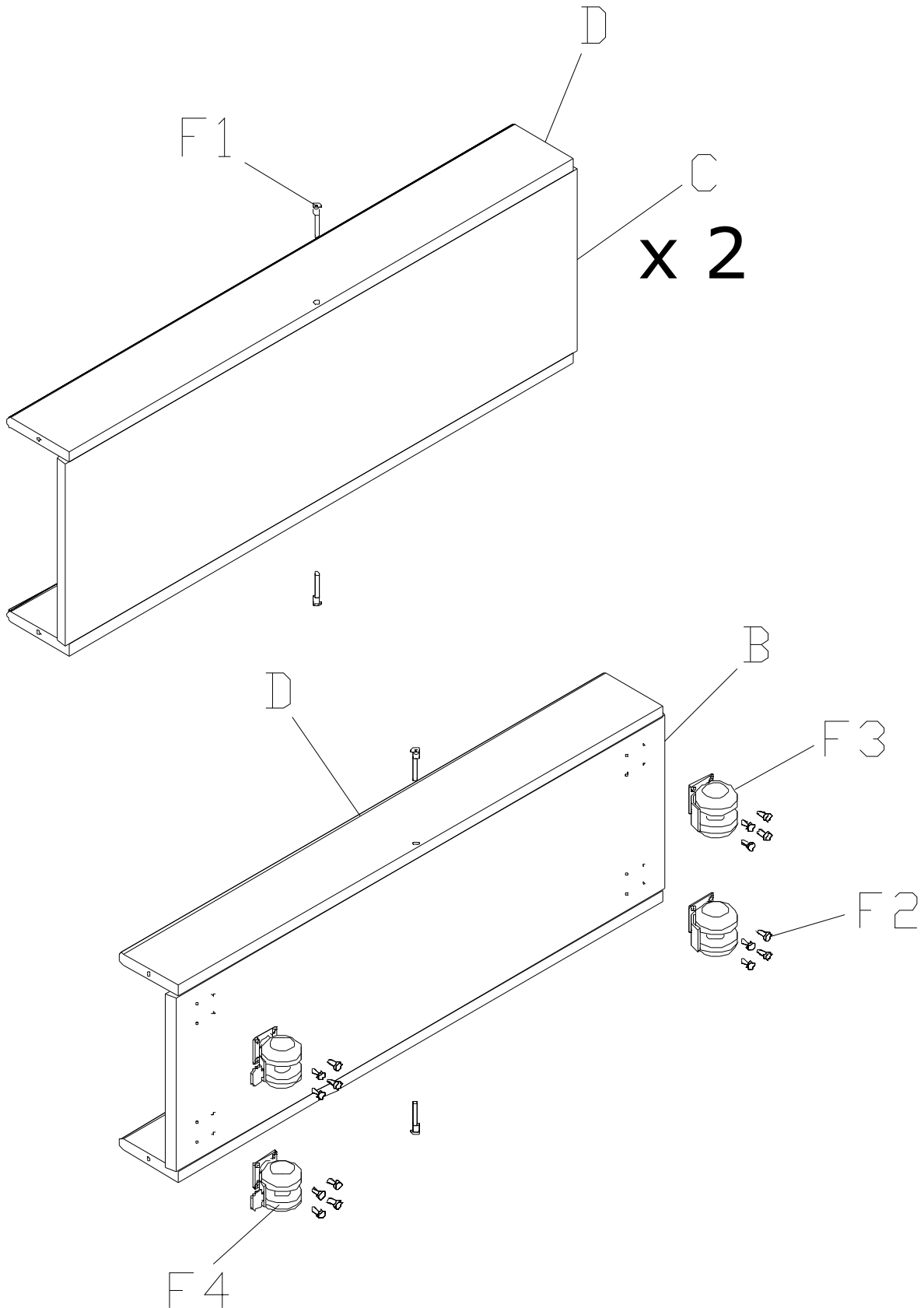

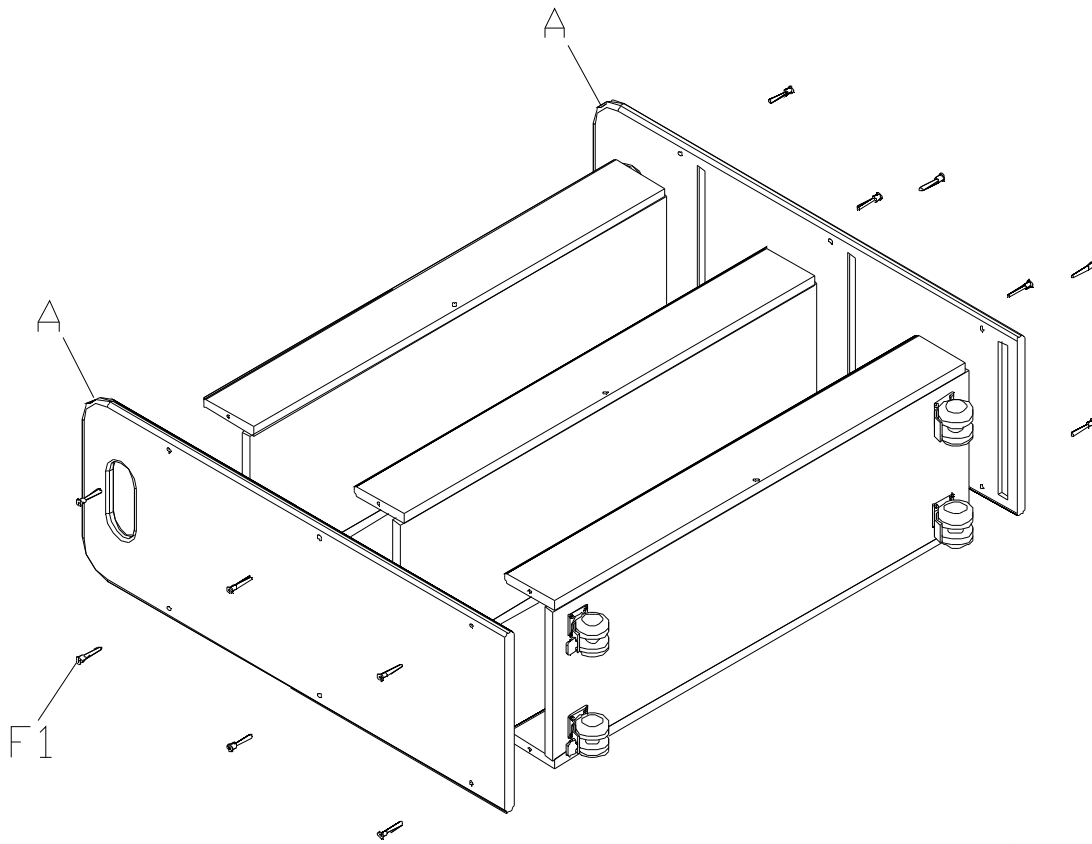

## The Lunchbox Trolley

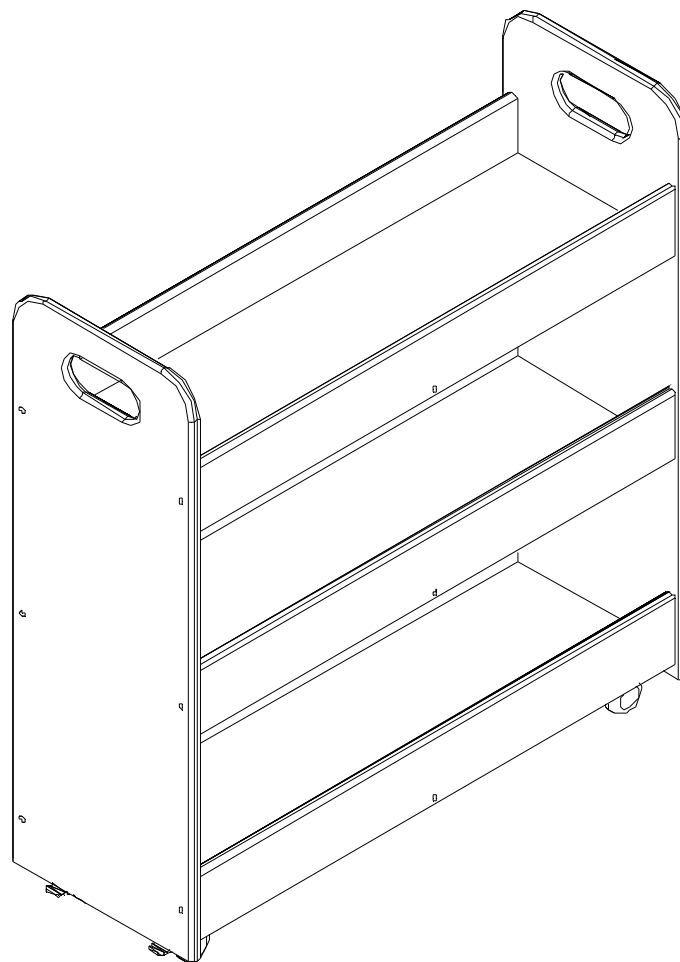

0920 - LUNCHBOX TROLLEY (CS0597)  
COMPONENTS LIST

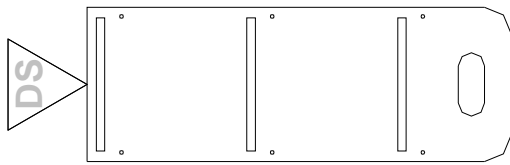

A  
PN: 0920103  
QTY 2



B  
PN: 0920204  
QTY 1

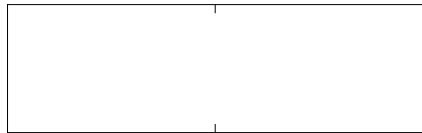

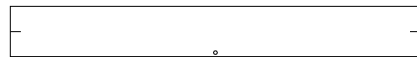

C  
PN: 0920303  
QTY 2



D  
PN: 0920403  
QTY 6

KIT  
(SOME EXTRA'S INCLUDED)

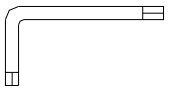
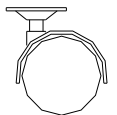
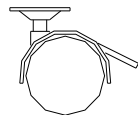
 F1 SUPERJOINER PN: FS6338SW4 QTY 20	 F2 PAN HEAD SCREW NO.10 x 1/2" PN: FS101/2P QTY 18	 ALLEN KEY PN: AMSW4 QTY 1
 F3 CASTOR C/W PLATE PN: ACGR50P QTY 2	 F4 CASTOR LOCKING C/W PLATE PN: ACGR50PB QTY 2	